

USING ACTIVE MAGNETIC BEARINGS FOR HIGH SPEED MACHINING – CONDITIONS AND BENEFITS

Jobst Görne,

HTW Aalen, Deutschland, e-mail: jobst.goerne@htw-aalen.de

Abstract: Active Magnetic Bearings offer high rotational speeds and high load carrying capacity. The rotor position is constantly controlled and can be changed within tenth of millimeters. These advantages are used to improve the performance of complex grinding operations when the process is designed correctly.

Keywords: magnetic bearings, design, spindles, grinding.

1. Design and Function of Active Magnetic Bearings

For a long time researchers have tried to use the magnetic effect to build bearings. Expected advantages were absence of friction and wear, precision of movement, reduction of heat and consumed power. First attempts were made with permanent magnets which turned out to have a low rigidity and need of at least one conventional

bearing. The use of electromagnets instead shows a huge problem: the balance of the bearing is instable and requires the control of the rotor.

Only few companies concentrate on building active magnetic bearings, S2M in France is one them. In the past they have been producing spindles suitable for the machining process. Picture 1 shows the basic concept of such a spindle /1/.

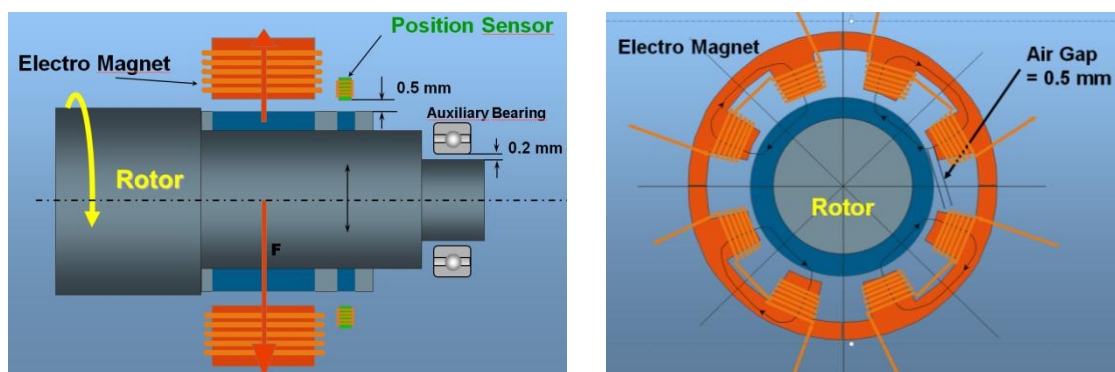

Picture 1: Basic Concept of an Active Magnetic Radial Bearing.

The rotor with rotor sheets (dark blue) is working in the stator (red). The shown configuration consists of 4 electro magnets, which exert attractive forces on the rotor. There is a remarkable air gap of about 0,5 mm between rotor and stator which gives way for an auxiliary roller

bearing in emergency cases. The clearance of the emergency bearing is much smaller (about 0,2 mm). This means that the rotor can move freely in a radial displacement window of about +/- 0,1 mm. The axial bearing is shown in Picture 2.

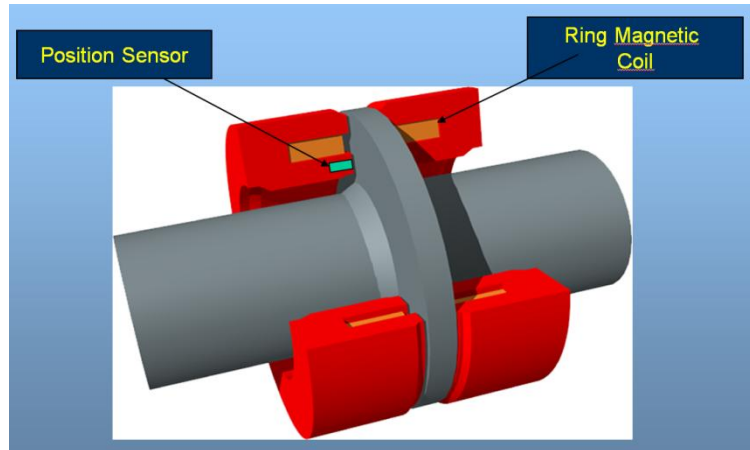

Picture 2: Active Magnetic Axial Bearing

There needs to be an axial thrust disk on the shaft. The magnetic bearing is coiled around the shaft, making the axial control easy. Active magnetic bearings do not possess a stable equilibrium. The force on the rotor increases when the rotor approaches one magnet. In order to keep the balance, the magnetic forces need to be

modified according to the current position of the rotor compared to the desired position. To this end position sensors are integrated into the bearings monitoring precisely the air gap in both, radial and axial direction. Picture 3 shows the flow diagram of the signals and control currents.

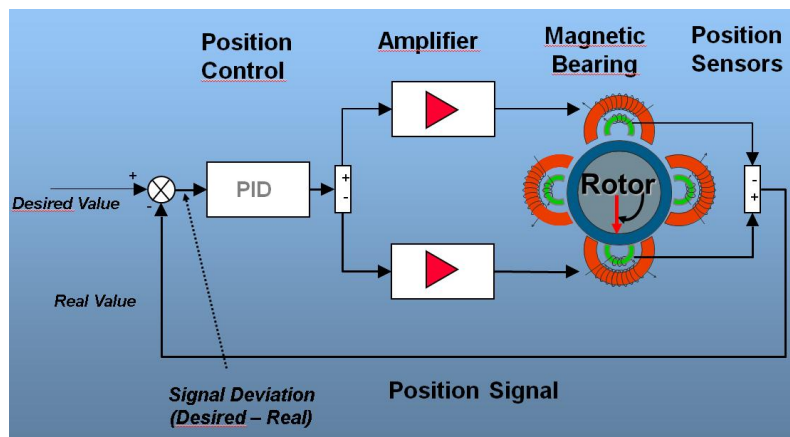

Picture 3: Flow Diagram of signals and control currents

Two sensors are combined to form a pair of sensors, doubling the resolution. Their signal is compared with a reference signal (desired value) and the difference is fed into the amplifiers. The amplifiers strengthen the magnetic field of the oppositemagnet of the rotor displacement, pulling back the rotor into position. The control logic used is PID, P meaning that the magnetic force is proportional to the displacement of the rotor, I means that the displacements are integrated over the time, eliminating even the smallest position errors and D means that the movement signal is differentiated, so the rotor acceleration is monitored, allowing to modify the magnetic

currents even before a safely detectable displacement of the rotor has taken place.

2 Properties of Active Magnetic Bearings

Among the most prominent properties of the AMB spindles is the high stiffness. Tests were made in the WZL in Aachen, comparing two spindle types, one conventional roller bearing spindle and one active magnetic bearing spindle, see picture 4. The results show a more than 5 times higher static stiffness of the AMB spindle. When it comes to dynamic stiffness, i.e. if the force is not constant but of a dynamic type (during

milling for example), the advantages of AMBspindles can be much higher, up to 50 times (250 Hz) over conventional spindles. Of course AMB spindles possess an eigen frequency as well

and careful actions have to be taken that the spindle is not run under such conditions as the damping behavior is very low.

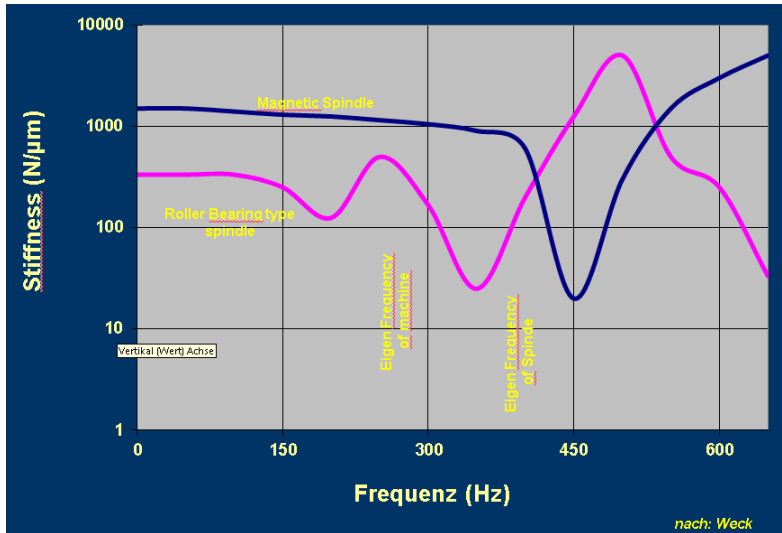

Picture 4: The stiffness of AMB Spindles is higher than in Conventional Bearings

The second very important advantage is the high speed capability. Conventional spindles are speed wise limited by their bearings. Roller bearings are characterized by a speed index called “ $n \times d_m$ ”,

which includes the mean bearing diameter. This index can be seen for average bearing values in picture 5.

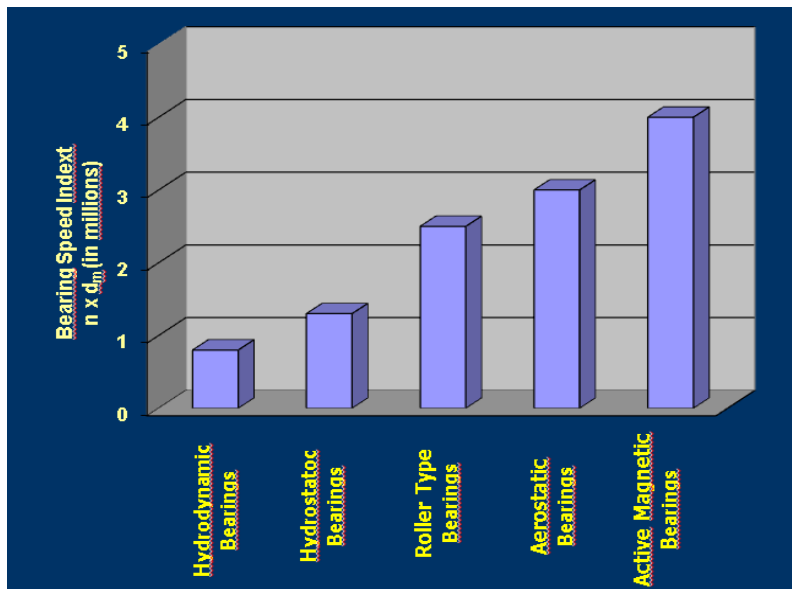

Picture 5: The Speed Index of AMB Bearings is significantly higher than Competitive Bearing Types

The speed limit of roller bearings is the centrifugal force on the rollers, whereas in magnetic bearings the centrifugal force on the rotor sheets limits the speed. Roller bearings speed can and will be improved by using ceramic

rollers (up to 4,5million $n \times d_m$ is reported), magnetic bearings will use carbon fiber bandages to increase the maximum speed (up to 6,8 million $n \times d_m$ has been reported /2/).

3 Benefit of High Speed Grinding

Research work done in the past 40 years has shown the great benefit of high cutting speeds for machining. Gühring found that cutting forces, roughness and tool wear are largely reduced and the maximum material removal rate can be increased /3/, when high cutting speeds are used

in grinding, picture 6. In order to understand the range of applied grinding speeds today still 30-45 m/s is the dominating speed, because this is what conventional grinding wheels allow. Kölling reports similar tendencies for shaft milling /4/. This means that high rotational speeds improve largely the machining processes.

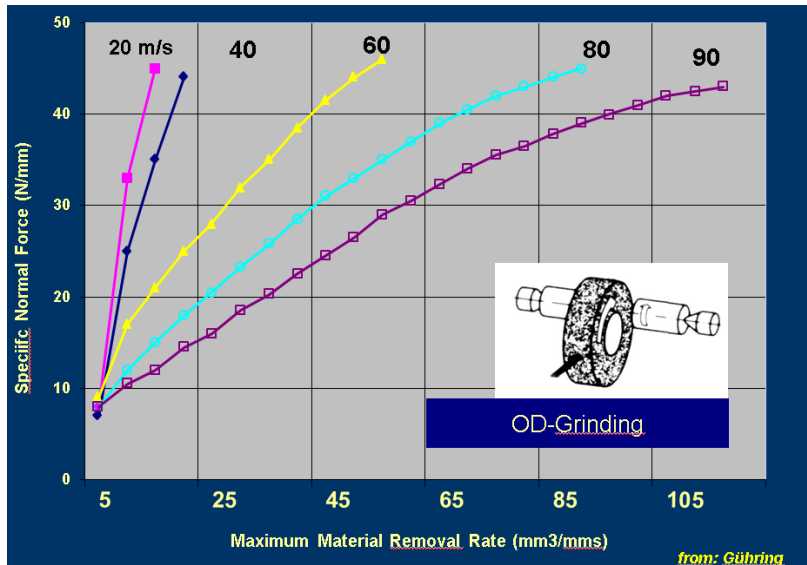

Picture 6: Using High Cutting Speeds reduces Grinding Normal Force Significantly

The need for high rotational speeds can be seen in picture 7. Mainly when it comes to small tool diameter, high RPM are required. Conventional cutting speeds of 30 m/s in grinding require about 48.000 rpm for a 12 mm dia tool, which is quite high for conventional spindles. If one wants to use

the advantages of high speed machining, speeds of up to 200.000 rpm need to be used. For the judgment of the usability of a certain spindle type of course the load carrying capability needs to be taken into consideration, too.

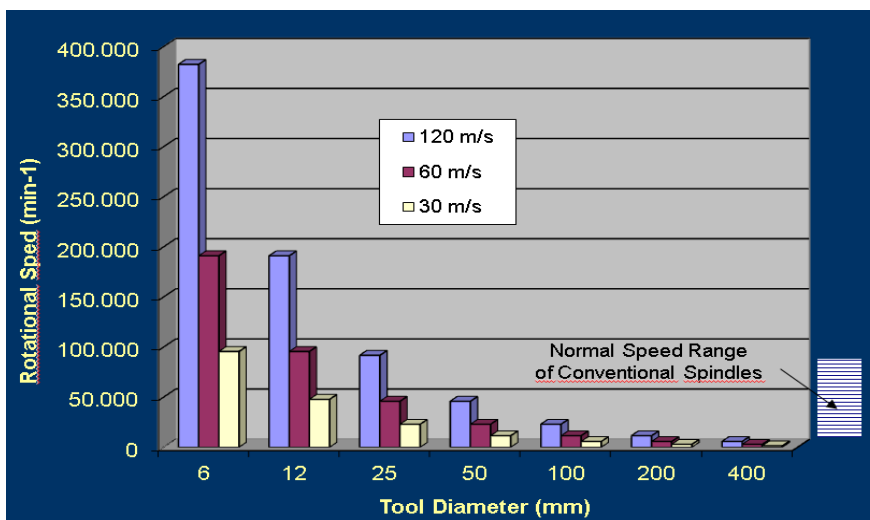

Picture 7: Small Tools Require Extreme Speeds to enable High Speed Machining

4. Examples of Successful Applications

One of the most successful applications of AMBspindles is the grinding of slots into hydraulic pump rotors of vane pumps, picture 8.

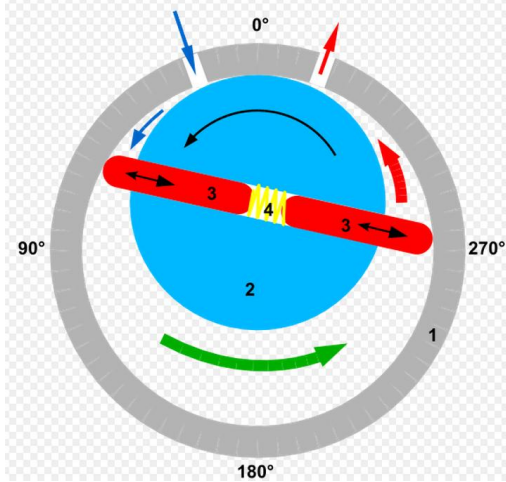

Picture 8: Principle of Rotor Vane Pump

The vanes slide in the slots of the rotor and separate the suction and compression chambers. A critical item of such a pump is the precision of the rotor slots, as oil may flow backwards, reducing the performance and the efficiency. The rotor is made from hardened steel, which leads to the fact that the slots need to be ground into the solid material. Picture 9 shows data of a real vane pump used in automotive applications. The slot is 8,5 mm deep and 1,25 mm wide. Such slots have been ground in the past with conventional grinding processes in multiple steps, taking a long time and consuming considerable amount of grinding wheels, as the grinding wheel required frequent dressing due to the extreme narrow width tolerance of 0,009 mm.

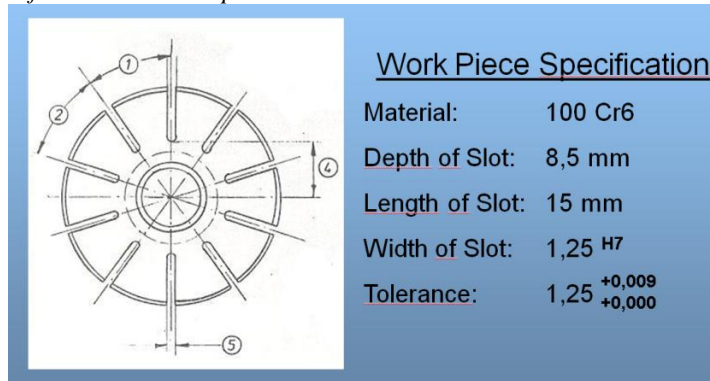

Picture 9: Data of a Sample Vane Pump

In order to improve the process and reduce part cost, high speed grinding with CBN-plated solid steel body grinding wheels was chosen /5/. An active magnetic bearing spindle was used to ensure the high rotational speed, allowing cutting speeds of 280 m/s. Process data can be found in picture 10.

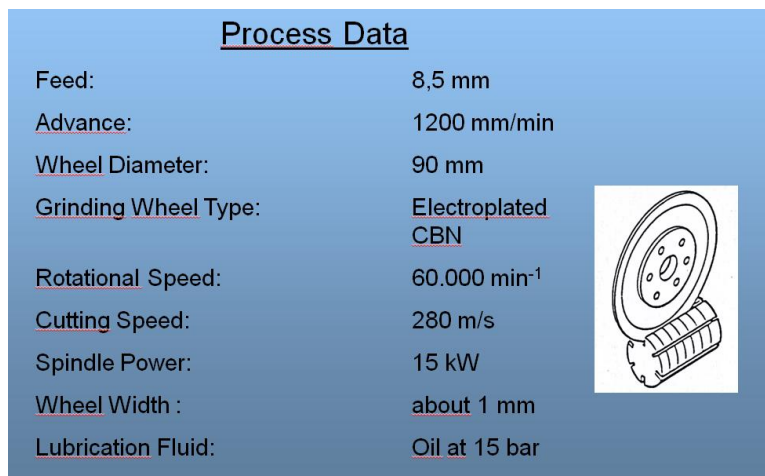

Picture 10: Process Parameters of Slot Grinding

It showed that the slots could be ground in one pass at full depth with a very high advance rate, showing the performance of the high speed grinding with CBN-wheels. The limits of the process could be found easily while establishing the process parameters. The control logic of the magnetic bearings generates a signal, which is proportional to the grinding force. This signal was monitored during first tests, allowing to increase the speeds and feeds until the load carrying capacity of the spindle was reached. The magnetic bearings offer another advantage for the slot grinding: as even the ultra-hard grits of Cubic Boron Nitride wear laterally on the

grinding wheel, the wheel loses its geometrical truth after a couple of hundred workpieces due to the narrow tolerances. As the cutting ability continues to be good, it would be a waste of grinding wheel life if the wheel would be taken out of production due to loss of width. For this reason the slot grinding process is separated into two steps: first a slot is ground into the solid material, using a wheel thickness of a bit over 1 mm. The generated slot width is then measured automatically and the remaining slot stock is machined off in a second pass. To this end the axial position of the wheel is changed in order to generate the true slot width, picture 11.

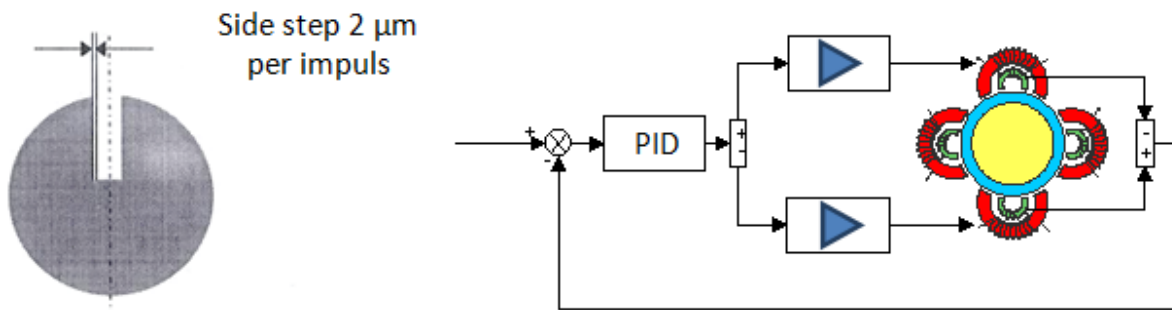

Picture 11: The Side Movement during Slot Grinding can be Achieved By Changing the Position of the Rotor

In order to do so, the machine reverses the advance, coming back through the slot in a slightly different axial position, grinding full depth but only in a very small area. The beauty of this process is that this axial movement can be done by the active magnetic bearing and no need exists to build a machine axis for this feed

direction. This increases stiffness, reduces cost and utilizes the features of the AMBspindle to the maximum. Picture 12 shows the difference in performance of the conventional process against the high speed process: the performance factor is about 14 between both processes.

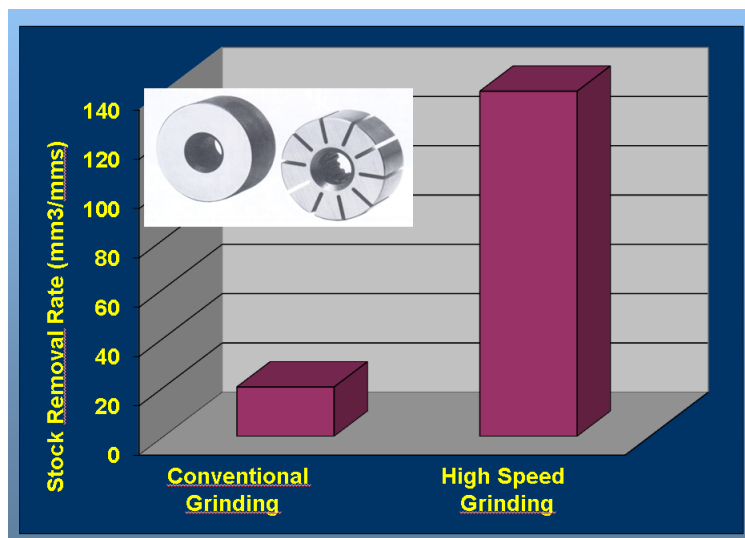

Picture 12: Performance Comparison of Conventional and High Speed Grinding

Another critical grinding process has been successfully solved by using high speed grinding with CBN wheels and a magnetic bearing spindle: the grinding of circlip grooves into pinions for automatic gear boxes. Grinding of slots into gears is characterized by an interrupted cut, this means

the high frequency of entry and exit of the contact between grinding wheel and tooth generates vibrations, which lead to a high wear of grinding wheels, resulting in frequent wheel redressing operations and frequent line stops for grinding wheel change, picture 13.

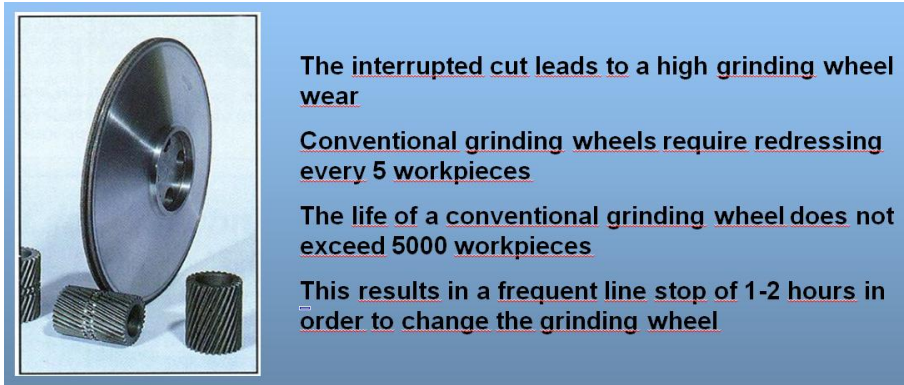

Picture 13: Problems during Slot Grinding of Pinions

Picture 14 gives the data of the used grinding wheel and spindle. Rotational speed was 20.000

rpm, installed spindle power 25 kW. Slot precision is +/-0,05 mm.



Picture 14: Grinding Data for High Speed Grinding of Pinion Grooves

After optimization of the grinding wheel and elimination of all possible deformations at the high rotational speed the process showed a

drastically improvement /6/. Obtained results are given in picture 15:

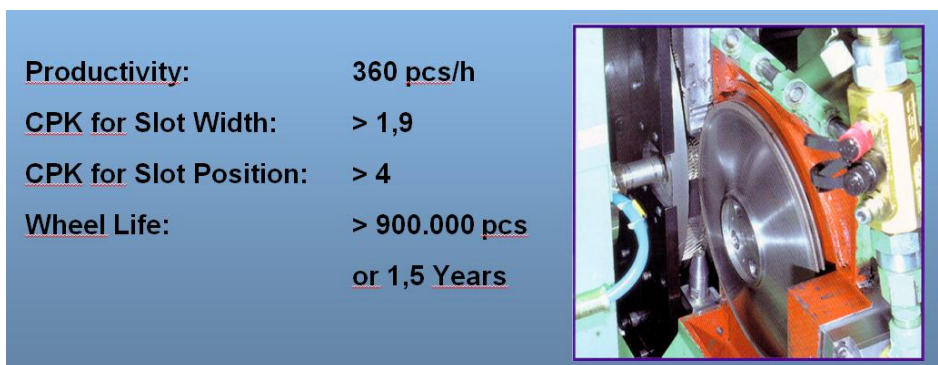

Picture 15: Obtained Results for High Speed Grinding of Pinion Grooves with AMB Spindles

The process shows that the basic problems of interrupted cut grinding have been overcome. Tool dressing is not necessary due to the mono layer wheel and wheel life has gone up so significantly, that the end customer can use the machine non-stop for over 1,5 years without any need to change the grinding wheel. Picture 16 shows the increase of tool life by a factor of about 180.

It must be said at this place that the machine technology needs to be adapted to the high speed

grinding. This means that the machine stiffness, its damping characteristic and the cooling conditions must be brought up to the state of the art. Using AMB spindles requires a high understanding of the electromechanical system. Sometimes the design staff at the machine tool manufacturer and the maintenance staff at the machine user need to have a completely different education in order to integrate the spindle or in order to maintain it.

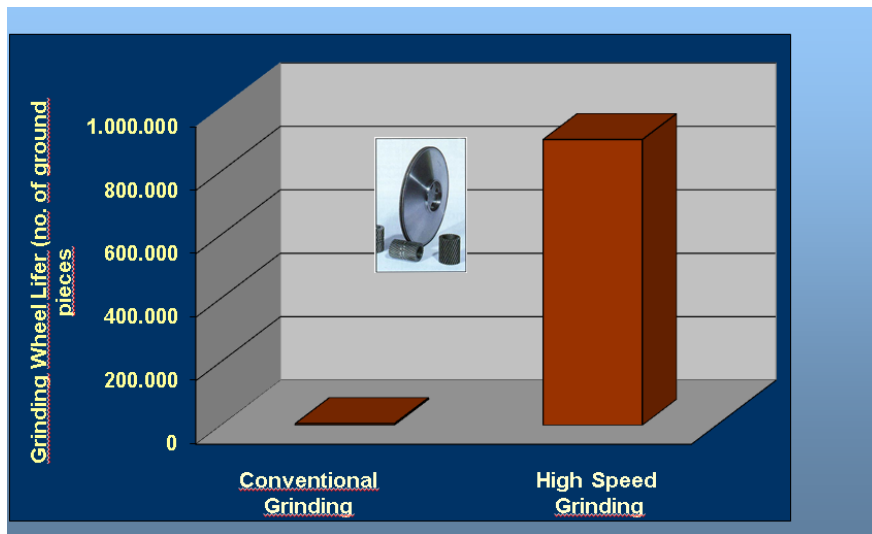

Picture 16: Tool life of Pignon Groove Grinding increases by Factor of 180

5 Summary

Critical grinding processes can be improved by the use of high speed grinding. In order to have the required rotational speeds, magnetic bearing spindles are ideal. They offer a lot of features, which conventional spindles cannot offer: integrated movements and force control. Usually AMB spindles are more powerful than conventional spindles.

Using the combination of electroplated CBN grinding wheels and AMB spindles has shown many advantages over conventional grinding. But the way to success is long and painful. New knowledge has to be made available in machine tool design and in the maintenance department of the end user.

Bibliography

[1]. S2M Pictures Courtesy of S2M, Vernon, France

- [2]. Schweizer Active magnetic bearings - chances and limitations International Centre for Magnetic Bearings, ETH Zurich, Found under: http://www.mcgs.ch/web-content/AMB-chances_and_limit.pdf
- [3]. Gühring Hochleistungsschleifen. Eine Methode zur Leistungssteigerung der Schleifverfahren durch hohe Schnittgeschwindigkeiten. Dissertation RWTH Aachen, 1967
- [4]. Kölling Schaftfräsen im Flugzeug- und Formenbau. Bericht über die 15. Arbeitstagung am 13.3.1986
- [5]. Kapp Personal Information given to the Author during a Visit Kapp GmbH, Coburg
- [6]. Diamant Board Personal Information given to the Author during a Visit Diamant Board, Brussels