

THE SPRINGBACK ANALYSE ON SHEET ALUMINUM V BENDING USING AN SYSTEMIC ANALYSIS ON BENDING OPERATION

Mihalache Ștefan¹, Nagiț Gheorghe², Chiorescu Dan³

59 A, Dimitrie Mangeron street, IASI-700050, ROMANIA
stmihalache@yahoo.com¹, nagit@tuiasi.ro², dan_chiorescu@yahoo.com³

Abstract: This article deals an important aspect of instability phenomen at sheet metal bending operation, namely the springback (the springback is an geometric phenomen that affects accuracy by changing the geometric shape). On sheet bending, the springback is defined as a difference between obtained forme and forme prescribed in drawing execution / desired forme. To realise the most credible research at springback phenomen developed at bending operation requires a systemic analysis highlighting the areas of interest at the process. The systemic analysis becomes unique character when it's transposed in relation to intended because the system can't be optimised than in relation to requirements. Based on research on systemic analysis of bending processing, analysis for establishing factors influencing the springbackphenomen, I realise a theoretical and experimental study which highlights how these factors influence the springback at the sheet aluminum V bending. Using FEM (Finit Element Method) in Ansys, i try an interpretation at springback phenomen on V-bending operation of the influences factors (bending force, thickness, punch radius). Using FEM analysis we observed the tension dispertion, places wich the springback effect is higher. Using Matlab software we observed the influences of two different factors on springback phenomen.

Keywords: V bending, sheet metal, springback, aluminum, FEM.

1. Introduction

The bending operation can be regarded as a modification, by an elastic – plastic alteration of the form of a blank after the plane bending around a straight edge. The bending processes are accompanied by strains that are due to the instability phenomena which accompany the processing. These instability phenomena occur during the bending process (the cracking, the breakage) as well as after the bending process (the bowing). Usually during the bending operation, the angle obtained after the bending does not equal the value of the angle of the punch with which the bending is made; most of the times this angle is larger, the difference between the angle obtained after the bending and the punch's angle represent the bowing. In the process of tin sheets strain, the inner radius of material bending is compressed and the outer radius is extended (Fig. 1). At the end of the strain, after the punch is no longer in contact with the piece and the loading is removed, the folded part of the metal is forced to

slowly regain its original shape. This phenomenon is known as the *elastic recovery*, being one of the most important instability phenomena which affect the quality of the strained parts. [1] The elastic recovery is an elastic nature phenomenon determined by the stress distribution on the section of the strained piece, stress which appears additionally to the internal stress introduced by means of the straining process. The distribution of the stress depends to a great extent to the achievement level of the plastic strain of the material. Changing the bending angle can be expressed by the so-called *bending angle* [2].

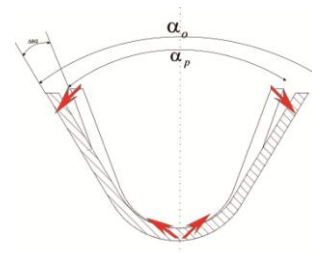

Figure 1: Springback phenomen

$$\Delta\theta = \alpha_o - \alpha_p .$$

(1)

Where: α_p – the punch’s angle, α_o – the piece’s angle after relaxation

To perform a research as reliable as possible of the bowing phenomenon developed at the bending operation of the tin sheets, a systemic analysis is necessary to highlight the interest areas of interest of the process.

The systemic approach is the unique direction of the development of the contemporary scientific research. The main distinguishing feature is that research is conducted within the limits of this approach and is directed towards the research of the characteristics of the objectives of the organized complex system. The systemic approach is a clear approach of a system in the research activity. The clarity with which the interest factors are exposed and especially the goals, enable the researchers the possibility to perform an efficient study.

The systemic analysis (Fig. 2) achieves matchlessness character when it is transposed with respect to the intended objective because a system cannot be optimized than in relation to requirements.

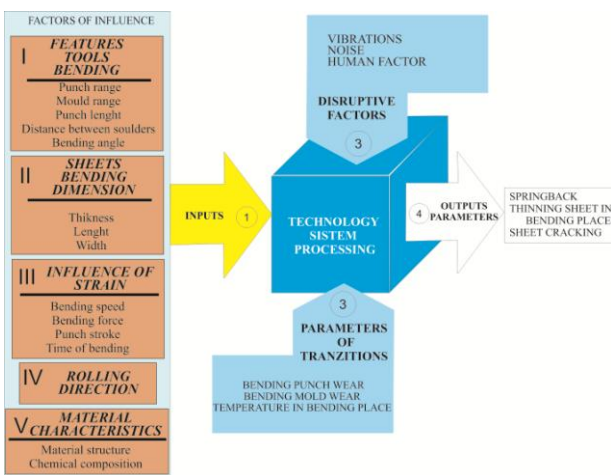

Figure 2: The systemic analysis

The systemic analysis performed in Figure 1 shows two areas: the design of the bending process / the technological system processing area

(area (A)) and a first picture of the experimental approach to be presented (area B).

- area A includes the following elements: the bending punch, the prism / the bending die sheet, the tin sheet subjected to bending.

- area B includes the following elements: the input parameters (1), the disrupters (2), the transition parameters (3) and the output parameters (4).

➤ **The input parameters (1)** are considered those parameters that are or may be adjustable before the operation and thus are mentioned parameters used in the experiment plan, variable factors such as:

a – vertex radius of the bending punch r_p [mm], b – radius of the prism/ the bending die sheet r_m [mm];

c – the l_p punch length [mm], d - distance between the shoulders of the bending sheet x_m [mm], s – the bending angle α [°].

a + b + c + d + e = I (features of the tools / active elements to be bent)

f – the sheet thickness subject to bending g [mm], g – the sheet length subjected to bending L [mm], h – the sheet width subjected to bending l [mm].

f + g + h = II (the sizes of the blank subjected to the bending operation)

i - bending speed v_i (m / min), j - bending force F_i (N), k - bending time t_i [sec], l – punch’s course c_p [mm].

i + j + k + l = III (the strain conditions when bending takes place)

m – the rolling direction (perpendicular to or parallel to the direction of bending).

m = IV (the rolling direction)

n - the structure of the material, a - chemical composition of the material.

n + o = V (the characteristics of the sheet material subjected to bending)

The well chosen input parameters of the bending process ensure precision to the sheet bending processing, a high quality of the parts obtained from the bending process (reduction of the bowing phenomenon / elastic recovery). All these changes in the status characteristics of the bent surfaces are made in an effort to meet the

production requirements and for an economic efficiency.

- **Disquieters (2)** are those parameters that occur during the processing, whose influence cannot be controlled or foreseen. The disquieters which influence the technological processing system are: p- the vibrations, r – the noise, to - the human factor.
- **The transition parameters (3)** are parameters that occur during the bending process, manifesting in a limited period of time (relatively short). Of the transition parameters we include: ξ - the bending punch wear, t – the bending die wear, T – the temperature in the bending area.
- **The output parameters (4)** are the errors / nonconformities that occur after the bending which determines the parts resulting from the bending process not to fall within the tolerances and limits prescribed in the shop drawing.

Of the output parameters we mention: u – the bowing / elastic recovery phenomenon, v – the thinning of the sheet in the bending area $r_p / g \leq 5$, z – sheet's breaking / cracking.

A characterization of the technological system for processing by plastic superficial cold deformation viewed as a single system is achieved by identifying its components (Fig. 3).

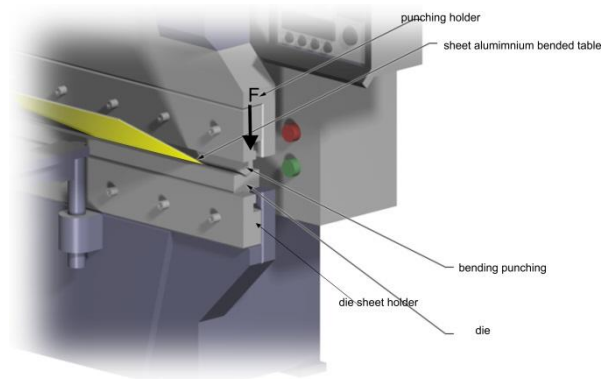

Figure 3: Components of the technological system

The components of the technological system of processing are: the bending punch and the punch sheet (driven by the F bending force), the prism / the die sheet and the die sheet holder.

Seen as a whole, but analyzed in a discretized method, the technological bending process by plastic superficial cold deformation has a contact

area, an area of the strains, of the deforming element, of the blank and the environment. Figure 4 shows a basic diagram of the bending process where are highlighted the study areas mentioned above.

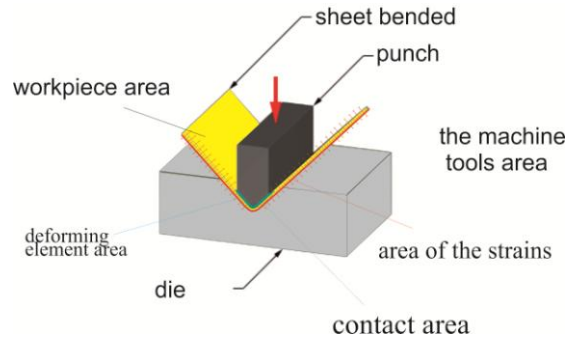

Figure 4: The bending technological process areas

The machine tool area is responsible for carrying out the process's kinematics and dynamics.

The deforming element (the bending punch) is a particularly important area in the bending process because by the nature of the material, size, geometry and its mechanical characteristics implicitly it prints on the processed sheet surface the desired profile. The influence parameters of the process related to the deforming element are the punch radius r_p , punch's height, the dimensions of both the active / the relief surfaces of the punch, the roughness of both the active / relief surfaces, the chemical composition of the punch as well as its hardness. Of all these influence parameters of the deforming element, the last three (the roughness, chemical composition and hardness) will not be considered as input variables. The reason why these parameters are not taken into account is the fact that they are related to the manufacturers of tools and industrial manufacturing devices.

The contact area is the surface where the bending punch under the bending force (F) comes into contact with the sheet subjected to the bending operation, sheet which is placed under the pressure exerted by the punch on the prism /

bending die. This area is present only during the use of force F of the bending punch.

The deformation area, is the area where the plastic deformation of the sheet occurs, being important for the study of the blank behaviour at deformation. This area is characterized by stress conditions and large deformations. In this area the material flow occurs. The size of this area is like the one presented, it depends on the kinematic and dynamic parameters of the process. The highlighting of these areas is possible by the analysis with finite element.

The blank is the main area of study. This is represented by the area not processed yet. The nature of the blank its properties (mechanical, physical, chemical, thermal treatment initially applied) have a great influence on the bending process. Parameters such as the size of the area where they are processed, the dimensions (length \times width \times thickness) of the blank, the initial state of the surface, the hardness of the material are input parameters provided by the blank and with influence on the process. The hardness of the material is one of the features which require an initial study because it is one of the parameters which cannot be changed during the operation and is related to characteristics on the stretching-strain limit of the material, its run-out limit. Information on the type of material being processed, its chemical composition as well as on an existing stress state, are needed to initiate the process.

The processed area is the area where are investigated the effects of the process on the blank. Here will be analyzed the effects of the applied mechanical treatment. The processed area is the area of the answers and of the analysis of the desired effects but also of the identification of the undesirable effects. The study of the processed area confirms or not the effectiveness of the bending process appliance, depending on the achievement or not of the desired properties. The dimensions of the obtained bending angle, the residual strain, the printed stress state, the operating resistance are analysis directions provided by the processed area surface.

2. Experimental Research

The experimental research aims to study the phenomenon of elastic recovery to the operation of aluminium sheets bending. The experiments were performed on the Abkant Farina press - type PFO / PS / N 110/30 (Fig. 5).



Figure 5: Farina abkant

The chemical analysis of the aluminium sheet was made in the testing laboratory at the Faculty of Science and Materials Engineering of Iasi using a Foundry Masters spectrometer (Fig. 6) and took place in three points by a scintillation process using the tungsten electrodes.

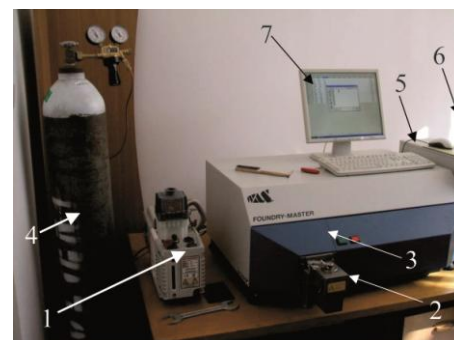

Figure 6: Foundry Masters Spectrometer

- 1) vacuum pump;
- 2) sparking stand;
- 3) spectral camera;
- 4) inert gas tube (high purity argon);
- 5) computer,
- 6) printer for analysis bulletins;
- 7) monitor

The chemical composition is shown in the tables below:

Table no. 1 The chemical composition of the aluminium sheet

Element	Al	Si	Fe	Cu	Mn	Mg
Compozitie (%)	99.6	0.002	0.278	0.01	0.0174	0.0001

Table no. 2 The chemical composition of the aluminium sheet

Element	Zn	Cr	Ni	Ti	Be	Cu
Compozitie (%)	0.005	0.008	0.005	0.0194	0.0001	0.0017

Table no. 3 The chemical composition of the aluminium sheet

Element	Li	Pb	Sn	Sr	V	Na
Compozitie (%)	0.0001	0.0027	0.01	0.0001	0.0137	0.0059

Table no. 4 The chemical composition of the aluminium sheet

Element	Bi	Zr	B	Ga	Co	Ag
Compozitie (%)	0.005	0.0056	0.01	0.0061	0.003	0.001

The study of the aluminium sheets bowing was made on a Abkant Farina press - type PFO / PS / N 110/30. Based on the relations of the tests to determine the size of the elastic recovery angle / bowing, it was observed the bowing angle dependence ($\Delta\theta$) of the size of the punch angle / bending angle (α_p), the thickness of the sheet subjected to bending (s), the radius of the bending punch (r_p), the bending force (F) [3], the nature of the material the sheet subjected to bending is made from (N_m) the rolling direction (dl). It is assumed valid the dependence of the bowing angle according to the above-mentioned parameters [4].

$$\Delta\theta = f(C_0, \alpha_p^{C1}, s^{C2}, r_p^{C3}, F^{C4}, N^{C5}, dl^{C6}, \dots) \quad (3)$$

For the hereby study is intended to determine the influence showed by the following factors: the sheet thickness (s), the vertex radius of the punch (R_p) and the bending strength (F) (whose values

are shown in Table 5) on the phenomenon of elastic recovery.

Tabel no. 5 (Variable parameters)

Sheet aluminium thickness (mm)	0.5	0.7	1
Bending force (N)	2000	2500	3000
Punch radius (R_p)	0,2	1,0	5,0

Performing successive bendings of the aluminium sheets of thicknesses (from 0.5 mm to 1.5 mm) at the bending with a bending punch with an angle of 60° is found that as the sheet thickness increases, the elastic recovery phenomenon decreases (table no. 6,7,8). Experimentally, the values copied in Tables no. 6,7,8 shall be obtained.

From the above mentioned tables, respectively from the graphical representation of fig. 7 it can be observed that at the same time with the increasing of the bending strength it decreases the elastic recovery phenomenon.

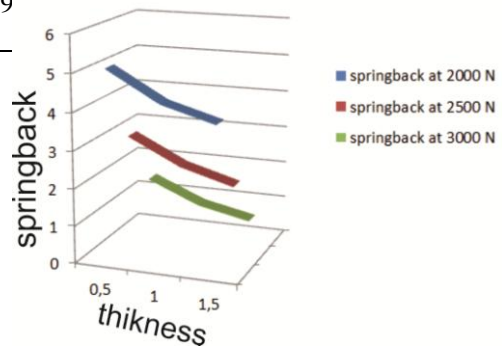

Figure 7: Springback variation at different bending forces and different material thickness

Being made operations of bending of the aluminium sheets with bending punches of 60° having the vertex radius: 0.2 mm, 0.5 mm, 5 mm is found that once the vertex radius of the bended punch increases, the phenomenon of elastic recovery increases (table no. 5). In Fig. 8 is shown how to increase the elastic recovery phenomenon. Table no. 5 (Variation of bowing depending on the vertex radius of the bended punch)

Thickness [mm]	0.5	1	1.5
$\Delta\theta [^\circ]$ R=5 mm	2	2,5	1
$\Delta\theta [^\circ]$ R=1 mm	1.7	1.5	0.7
$\Delta\theta [^\circ]$ R=0.2 mm	1.5	1	0.5

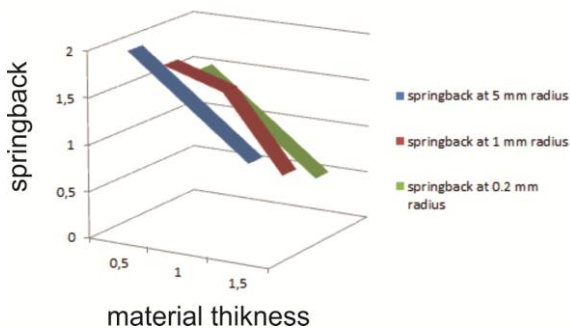

Figure 8: Springback variation at different punch radius

3. Simulation with a finite element

To highlight how the deformations evolve during the bending process it is made a simulation with a finite element using the ANSIS programme [5]. Firstly, they will be formed using the Catya programme the two active parts of the bending process that is: the punch and the die.

Firstly is 3D shaped the sheet which is going to be bent (40 x 10 x 0.5 mm), the bending punch (bending angle of 60 °), the plate bending die in the Catia module- Part Design. The sheet is considered made of aluminium, with the following physical properties: Young's modulus: 7e+010 N/m², the Poisson coefficient: 0.346, density: 2710 kg/m³, thermal expansion coefficient: 2.36e-005_Kdeg, and allowable resistance: 9.5 s+007 N/m².

There will be made a simulation of the bending with a punch of 60°, radius 0.2 mm and 5.0 mm with a bending force of 2000 N. It is found that the high-stress area is present in the contact area proper to the radius of the bending punch. The further we go from this area, the smaller the stress will be. The difference between the punch bending with a radius of 5.0 mm respectively the punch bending with a radius of 0.2 mm is that with the latter, the risk of the material cracking increases as the punch is coming in contact with the sheet on a distance of more 5.72mm (Figure 9, 10).

According to the graphical representation of fig. 10 it is found that the aluminium sheets

subjected to the punch bending of 0.2 or 5.0 mm will resist to the applied bending force.

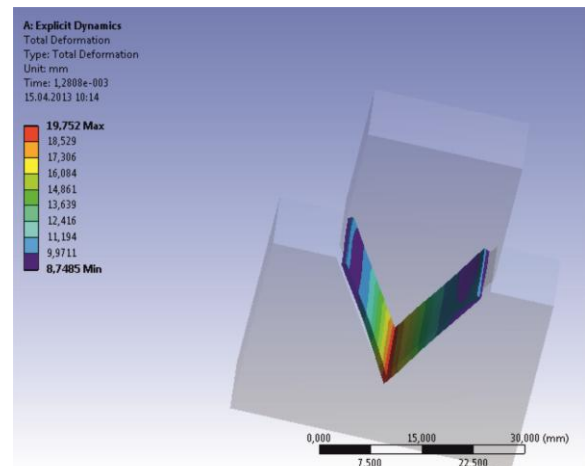

Figure 9: bending simulation with punching radius at 0.2 mm.

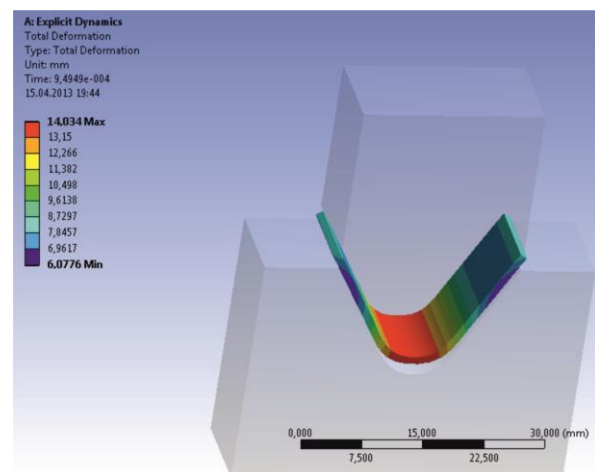

Figure 10: bending simulation with punching radius at 5.0 mm.

4. Conclusions

The sheet thickness subjected to bending is a first factor of influence affecting the elastic recovery phenomenon. According to the diagram of fig. 7 the elastic recovery phenomenon of the aluminium sheets decreases with the increase thickness. Also in fig. 7 is found that at the same time with the increase of the bending force the elastic recovery phenomenon will diminish. The increase of the elastic recovery force determines the increases of the value of these tensions. Therefore, the stress distribution in the direction

of the thickness of the material is more uniform, thus reducing the elastic recovery.

A third studied factor is the vertex radius of the bended punch. Thus, as expressed in Fig. 8, the more the vertex radius of the punch decreases, the more the elastic recovery phenomenon shall diminish.

References

- [1] VukotaBoljanovic - Sheet Metal Forming Processes and die design, Industrial Press, N Y 2004.
- [2] Iliescu C. – Tehnologiapresarii la rece, ed. DidacticasiPedagogicaBucuresti, 1984
- [3] Narayanasamy R. – Application of response surface methodology for predicting bend force during air bending process in interstitial free steel sheet, J. Adv. Manuf. Techn. 44 (2009) 38-48.
- [4] Wang Jyhwen – Springback control of sheet metal air bending process, J. of Manufacturing Processes, 10 (2008, 21-27).
- [5] HimanshuGajjar V. – Finite Element Analysis of sheet metal air bending using hyperform LS-DYNA, J. World Academy of Science, Engineering and Technology 32, (2007), 92-97.